

HTC PCB & Heatsink Mounting Specifications

This document is to provide information on how to mount the HTC to the evaluation board and how to attach the heatsink to the HTC.

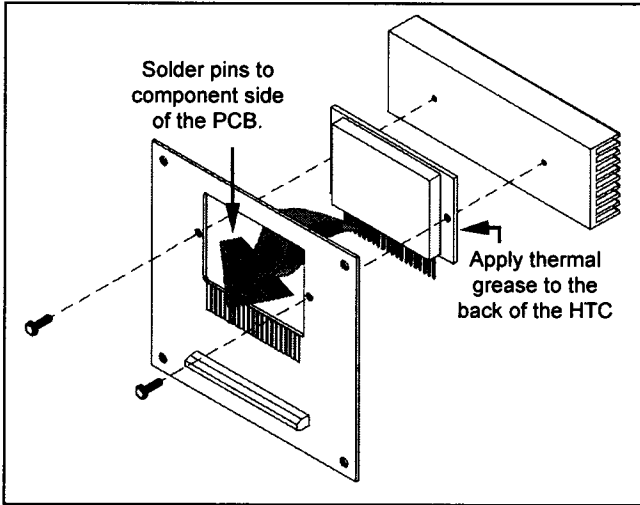

Assembly of HTCPCB evaluation (99-840008)

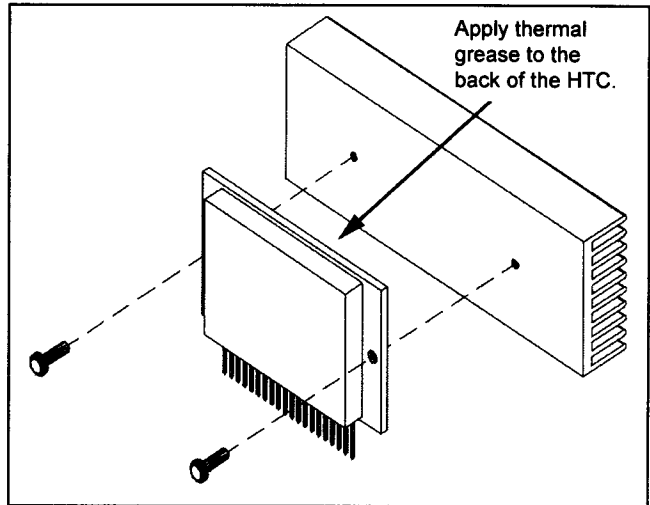

Assembly of HTC heatsink (99-850000)

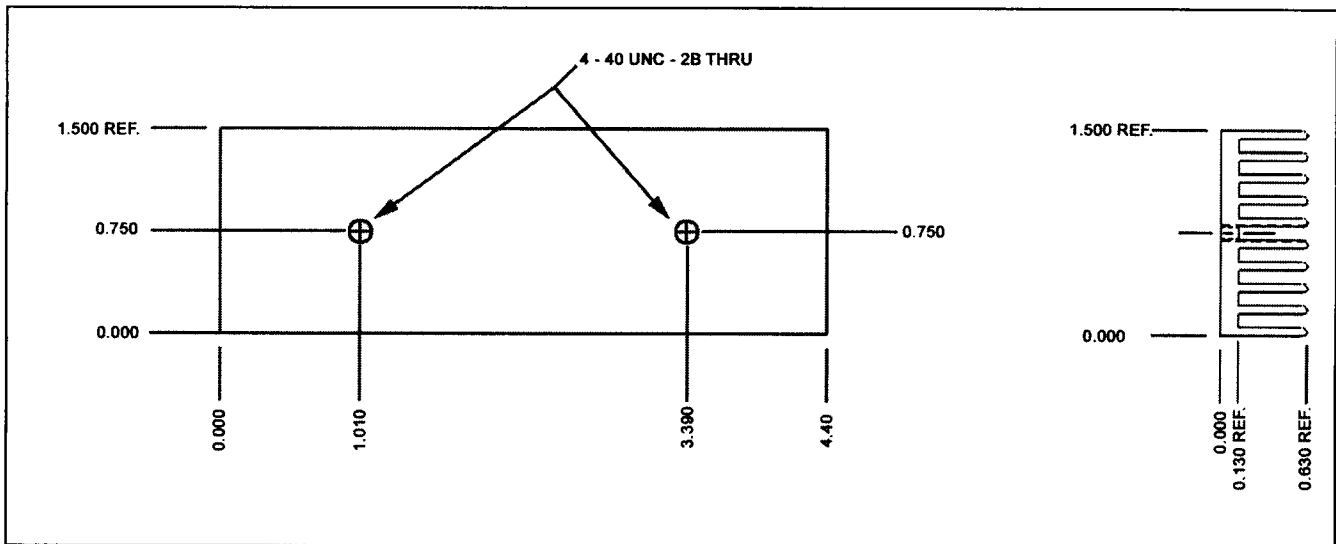

All dimensions are in inches.

Wavelength recommends the following thermal grease:
 Model #TG-001, 14 gram packet, coverage 14² inch, thermal conductivity 0.735.
 This can be obtained from MELCOR Corp., 1040 Spruce Street, Trenton, NJ 08648
 Phone # 609-393-4178 www.melcor.com.